

NiCd Accus 4.5 Ah

Nickel-Cadmium cells (NiCd)



Stick; Connection: blade terminal



Stick + Stick; Connection: blade terminal



Side by side; Connection: plug terminal

Product description

- _ High-temperature NiCd cells for use with emergency lighting unit
- _ Please note that due to EU law, this article is available for purchasing only outside of the European Union.
- _ 4 year design life
- _ 2 years guarantee (Conditions at <https://www.tridonic.com/en/int/services/manufacturer-guarantee-conditions>)

Properties

- _ Constant high-temperature operation – depending on the emergency lighting unit used (refer to respective emergency control gear data sheet)
- _ Good charging properties at high temperature
- _ High energy maintenance of the charged battery
- _ Certified quality manufacturer
- _ In various configurations
- _ Simple connection with blade terminal respectively plug terminal
- _ With polycarbonate fixing caps and connecting cable
- _ Electrical connection with mounted end caps possible
- _ Suitable for emergency lighting equipment as per IEC 60598-2-22

Website

<http://www.tridonic.com/89800092>



NiCd Accus 4.5 Ah

Nickel-Cadmium cells (NiCd)

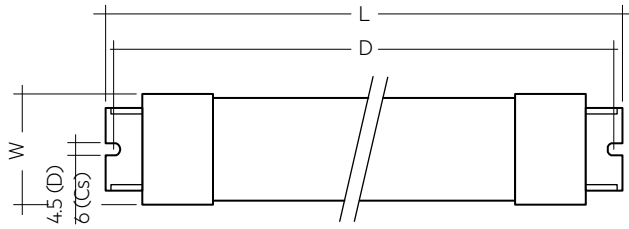

Stick; Connection: blade terminal

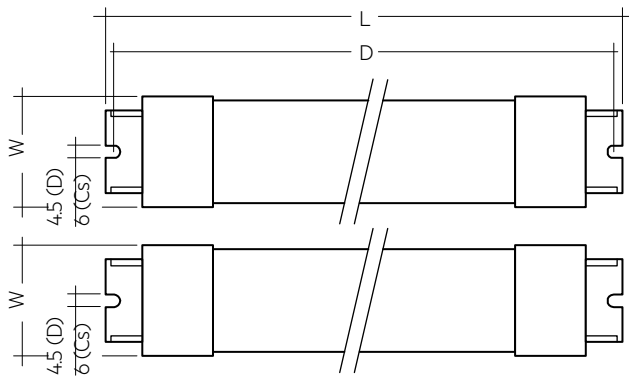

Stick + Stick; Connection: blade terminal

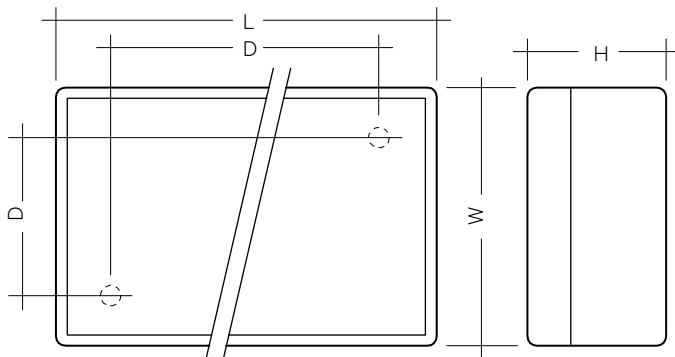

Side by side; Connection: blade terminal

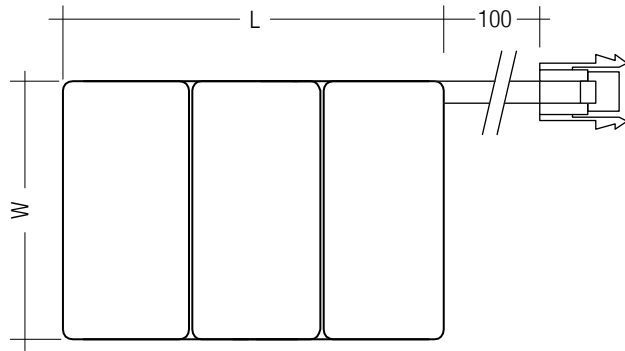

Side by side; Connection: plug terminal

Ordering data

Type	Article number	Capacity	Packaging, carton	Packaging, outer box	Weight per pc.
NiCd D cells – stick					
Accu-NiCd 2A 55	89800092	4.5 Ah	5 pc(s).	25 pc(s).	0.255 kg
Accu-NiCd 3A 55	28002773	4.5 Ah	5 pc(s).	25 pc(s).	0.424 kg
Accu-NiCd 3A	89895960	4.2 Ah	5 pc(s).	25 pc(s).	0.386 kg
Accu-NiCd 4A 55	89800089	4.5 Ah	5 pc(s).	25 pc(s).	0.500 kg
Accu-NiCd 5A 55	28002774	4.5 Ah	5 pc(s).	25 pc(s).	0.680 kg
NiCd D cells – stick + stick					
Accu-NiCd 4C 55	28002775	4.5 Ah	5 pc(s).	25 pc(s).	0.608 kg
Accu-NiCd 5C 55	89800090	4.5 Ah	5 pc(s).	25 pc(s).	0.700 kg
Accu-NiCd 6C 55	89800388	4.5 Ah	5 pc(s).	25 pc(s).	0.756 kg
NiCd D cells – side by side					
Accu-NiCd 3B 55	89800384	4.5 Ah	5 pc(s).	25 pc(s).	0.380 kg
Accu-NiCd 4B 55	89800385	4.5 Ah	5 pc(s).	25 pc(s).	0.588 kg

Technical data

Battery voltage per cell	1.2 V
Min. battery casing temp. (design life of 4 years)	+ 5 °C
Max. battery casing temp. (design life of 4 years)	Refer to emergency control gear datasheet

Standards

according to EN 60598-2-22

Specific technical data

Type	Article number	Number of cells	Capacit y	Length L	Hole spacing D	Hole spacing D	Width B	Height H
NiCd D cells – stick								
Accu-NiCd 2A 55	89800092	2	4.5 Ah	146 mm	-	125 mm	36 mm	35 mm
Accu-NiCd 3A 55	28002773	3	4.5 Ah	212 mm	-	192 mm	36 mm	35 mm
Accu-NiCd 3A	89895960	3	4.2 Ah	210 mm	-	198 mm	36 mm	35 mm
Accu-NiCd 4A 55	89800089	4	4.5 Ah	263 mm	-	242 mm	36 mm	35 mm
Accu-NiCd 5A 55	28002774	5	4.5 Ah	331 mm	-	311 mm	36 mm	35 mm
NiCd D cells – stick + stick								
Accu-NiCd 4C 55	28002775	4	4.5 Ah	146 + 146 mm	-	125 + 125 mm	36 mm	35 mm
Accu-NiCd 5C 55	89800090	5	4.5 Ah	212 + 146 mm	-	192 + 125 mm	36 mm	35 mm
Accu-NiCd 6C 55	89800388	6	4.5 Ah	212 + 212 mm	-	192 + 192 mm	36 mm	35 mm
NiCd D cells – side by side								
Accu-NiCd 3B 55	89800384	3	4.5 Ah	98 mm	32 x 40 mm	-	63 mm	35 mm
Accu-NiCd 4B 55	89800385	4	4.5 Ah	131 mm	64 x 40 mm	-	63 mm	35 mm

1. Standards

The battery cells are designed to comply with the IEC international standard and tested according to the normative permanent charge endurance test described in the IEC 61951-1 standard. This performance is mandatory for use in Emergency Lighting Units to comply with the IEC 60598 2.22.

1.1 Glow-wire test

according to EN 61347-1 with increased temperature of 960 °C passed (valid for connectors and caps).

2. Thermal data

2.1 Storage conditions

- Avoid atmosphere with corrosive gas
- Disconnect batteries before storage or delivery
- Avoid storage of discharged batteries
- Store batteries within the specified temperature range in low humidity conditions. Optimal storage conditions are:
 - relative humidity: < 65 %
 - temperature: -20 ... +30 °C for up to 6 months after printed date of manufacture. If the batteries are stored for longer than 6 months, it is recommended to recharge to 50% of the full capacity. After this the batteries can be stored for another 6 months. With this method, a maximum storage time of 12 months can be achieved.
 - temperature: -20 ... +25 °C for up to 12 months after printed date of manufacture
- A long term storage in open circuit leads to battery self discharge and deactivation of chemical components. It could be required to charge and discharge the batteries a few times to recover the initial performance.

3. Installation & commissioning

3.1 Activating NiCd batteries

When using rechargeable NiCd batteries for emergency lighting the following point is essential in order to achieve the expected operating time of the batteries:

In order to activate new batteries, 2-3 full charging-discharging can be needed to make sure batteries achieve their rated capacity. This activating process is defined by running 2-3 full charging (24 hrs) and discharging (1/2/3 hrs) cycles of the batteries. If the first duration test fails, please repeat the test once again after a 24 hour charging period.

3.2 Avoidance of excessive discharge cycles

During building installations, in many cases, mains supply is not available on a permanent 24-hour basis which then leads to unwanted, uncontrolled excessive discharge cycles. This has a very strong effect on the design life time of the battery. Make sure that in such situations, the battery remains disconnected in the luminaire till the mains power supply is stable on a 24-hour basis.

It is strongly recommended to refer to the datasheets of Tridonic emergency control gears to avoid excessive discharge cycles. At the same time, make sure that this information is handed over to the installation staff / electrician in order to ensure a proper way of installation and commissioning.

3.3 Avoidance of deep-discharge conditions

It is very important that NiCd batteries are not left connected for long periods in a discharged state. Following options may lead to a deep discharge situation and must be avoided:

- Storage periods of rechargeable batteries of over 6 month without recharging the battery packs.

- Shipment, storage of assembled emergency luminaires with battery pack connected to the emergency driver.
- Long periods of mains-interruptions of more than two weeks, once, the emergency system is installed and the battery pack is connected to the emergency driver.

4. Mechanical details

4.1 Mechanical details for batteries with blade terminals

4.1.1 Battery leads

- Delivery quantity: 1 red and 1 black
- Length: 1,300 mm
- Wire type: 0.5 mm² solid conductor
- Insulation temperature rating: 90 °C

4.1.2 Battery end termination

Push on 4.8 mm receptacle to suit battery soade fitted with insulating cover

4.1.3 Emergency lighting unit end termination

8.0 mm stripped insulation

4.1.4 Batteries

Connection method: 4.8 x 0.5 mm spade tag welded to end of cell.

For stick packs this connection is accessible after the battery caps have been fitted.

Two-piece batteries are supplied with a 200 mm lead with 4.8 mm receptacles at each end and insulating covers to connect the separate sticks together. Connect two battery sticks in series by connecting plus to minus.

To inhibit inverter operation disconnect the batteries by removing the connector from the battery spade tag.

4.2 Mechanical details for batteries with plug terminals

4.2.1 Battery leads

- Quantity: 1 red and 1 black with plug terminals
- Length: 1 m
- Battery connection: 0.1 m with connector
- Wire type: 0.5 mm² solid conductor
- Insulation temperature rating: 90 °C
- Polarity: red (positiv +), black (negative -)

4.2.2 Battery end termination

Plug terminals

4.2.3 Emergency lighting unit end termination

8.0 mm stripped insulation

4.2.4 Batteries

Connection method: 2-pole plug connection

To inhibit inverter operation disconnect the batteries by removing the connector from the battery spade tag.

5. Technical data Accu

Capacity			
Rated minimum capacity	1.6 Ah	4.2 Ah	4.5 Ah
Typical weight per cell	45 g	124 g	124 g
Cell dimensions			
Diameter	22.5 mm	32.5 mm	32.5 mm
Height	42.5 mm	60.5 mm	60.5 mm

Consult individual emergency control gear data sheet for maximum allowable temperatures and allowed number of discharge cycles.

6. Safety

- Do not short-circuit the battery pack – when installing the luminaire make sure sharp edges do not come into contact with cables.
- Do not open or damage the battery pack or throw it into a fire.
- Protect the battery against moisture and keep away from water.
- Do not expose the battery to direct sunlight or excessive heat (see storage conditions).
- Transport and store the battery only in its original packaging.
- Comply with the transport conditions of the transport company.
- Follow the instructions on the safety data sheets.



Damage/improper use

If the battery is damaged or user incorrectly vapours and liquids may escape from it. If you come into contact with battery fluid wash immediate with water and seek medical assistance if necessary.

7. Disposal

- Do not dispose of batteries with normal waste.
- Comply with local regulations when disposing of batteries.

8. Miscellaneous

8.1 Additional information

Additional technical information at www.tridonic.com → Technical Data

Lifetime declarations are informative and represent no warranty claim.
No warranty if battery was opened.