

NiMH Accus 2.2 Ah

Nickel-Metal Hydride cells (NiMH)



Stick



Stick + Stick



Side by side

Product description

- _ High-temperature NiMH cells for use with emergency lighting units
- _ 4 year design life
- _ 2 years guarantee (conditions at <https://www.tridonic.com/en/int/services/manufacturer-guarantee-conditions>)

Properties

- _ Cadmium free
- _ Constant high-temperature operation – depending on the emergency lighting unit used (refer to respective emergency control gear data sheet)
- _ Low profile cross-section 23 mm (without end caps)
- _ Good charging properties at high temperature
- _ High energy maintenance of the charged battery
- _ Certified quality manufacturer
- _ In various configurations
- _ Simple connection with blade terminal
- _ With polycarbonate fixing caps and connecting cable
- _ Electrical connection with mounted end caps possible
- _ Suitable for emergency lighting equipment as per IEC 60598-2-22

Website

<http://www.tridonic.com/28002087>

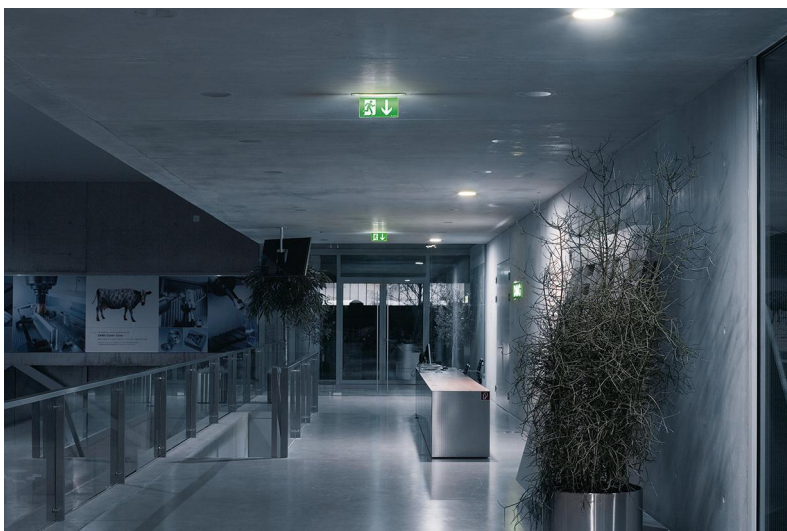

NiMH Accus 2.2 Ah

Nickel-Metal Hydride cells (NiMH)

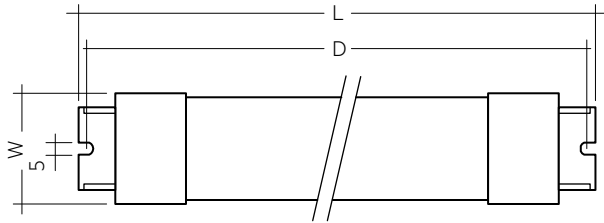

Stick

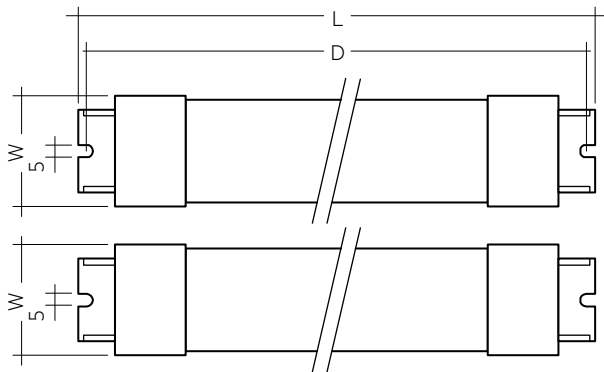

Stick + Stick

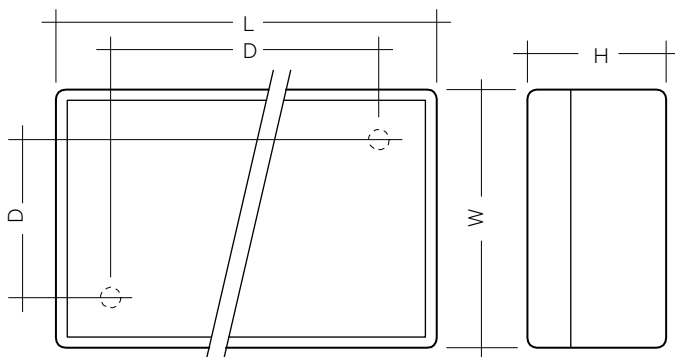

Side by side

Ordering data

| Type | Article number | Number of cells | Capacity | Packaging, carton | Packaging, outer box | Weight per pc. |
|--|----------------|-----------------|----------|-------------------|----------------------|----------------|
| NiMH Cs cells – stick, 2,2 Ah | | | | | | |
| Accu-NiMH 2.2Ah 2A | 28002087 | 2 | 2.2 Ah | 5 pc(s). | 25 pc(s). | 0.106 kg |
| Accu-NiMH 2.2Ah 3A | 28002088 | 3 | 2.2 Ah | 5 pc(s). | 25 pc(s). | 0.188 kg |
| Accu-NiMH 2.2Ah 4A | 28002089 | 4 | 2.2 Ah | 5 pc(s). | 25 pc(s). | 0.246 kg |
| Accu-NiMH 2.2Ah 5A | 28002090 | 5 | 2.2 Ah | 5 pc(s). | 25 pc(s). | 0.298 kg |
| Accu-NiMH 2.2Ah 6A | 28002091 | 6 | 2.2 Ah | 5 pc(s). | 25 pc(s). | 0.360 kg |
| NiMH Cs cells – stick + stick, 2,2 Ah | | | | | | |
| Accu-NiMH 2.2Ah 6C | 28002092 | 6 | 2.2 Ah | 5 pc(s). | 25 pc(s). | 0.364 kg |
| NiMH Cs cells – side by side, 2,2 Ah | | | | | | |
| Accu-NiMH 2.2Ah 5B | 28002093 | 5 | 2.2 Ah | 5 pc(s). | 25 pc(s). | 0.310 kg |

Technical data

| | |
|--|---|
| Battery voltage per cell | 1.2 V |
| Min. battery casing temp. (design life of 4 years) | 5 °C |
| Max. battery casing temp. (design life of 4 years) | Refer to emergency control gear datasheet |

Standards

according to EN 60598-2-22

Specific technical data

| Type | Article number | Number of cells | Capacity | Length L | Hole spacing D | Hole spacing D | Width B | Height H |
|--|----------------|-----------------|----------|-------------|-------------------|-------------------|---------|-------------|
| NiMH Cs cells – stick, 2,2 Ah | | | | | | | | |
| Accu-NiMH 2.2Ah 2A | 28002087 | 2 | 2.2 Ah | 125 mm | - | 109 mm | 28.0 mm | 27.0 mm |
| Accu-NiMH 2.2Ah 3A | 28002088 | 3 | 2.2 Ah | 167 mm | - | 152 mm | 28.0 mm | 27.0 mm |
| Accu-NiMH 2.2Ah 4A | 28002089 | 4 | 2.2 Ah | 209 mm | - | 194 mm | 28.0 mm | 27.0 mm |
| Accu-NiMH 2.2Ah 5A | 28002090 | 5 | 2.2 Ah | 252 mm | - | 237 mm | 28.0 mm | 27.0 mm |
| Accu-NiMH 2.2Ah 6A | 28002091 | 6 | 2.2 Ah | 294 mm | - | 280 mm | 28.0 mm | 27.0 mm |
| NiMH Cs cells – stick + stick, 2,2 Ah | | | | | | | | |
| Accu-NiMH 2.2Ah 6C | 28002092 | 6 | 2.2 Ah | 167 mm | - | 152 mm | 28.0 mm | 27.0 mm |
| NiMH Cs cells – side by side, 2,2 Ah | | | | | | | | |
| Accu-NiMH 2.2Ah 5B | 28002093 | 5 | 2.2 Ah | 134 mm | 24 x 112 mm | - | 48.5 mm | 28.5 mm |

1. Standards

The battery cells are designed to comply with the IEC international standard and tested according to the normative permanent charge endurance test described in the IEC 61951-2 standard. This performance is mandatory for use in Emergency Lighting Units to comply with the IEC 60598 2.22.

1.1 Glow-wire test

according to EN 61347-1 with increased temperature of 850 °C passed (valid for connectors and caps).

2. Thermal data

2.1 Storage conditions

- Avoid atmosphere with corrosive gas
- Disconnect batteries before store or delivery
- Avoid storage of discharged batteries
- Store batteries within the specified temperature range in low humidity conditions. Optimal storage conditions are:
 - relative humidity: < 60 %
 - temperature: -20 ... +25 °C for up to 12 months after printed date of manufacture
- A long term storage in open circuit leads to battery self discharge and deactivation of chemical components. It could be required to charge and discharge the batteries a few times to recover the initial performance.

3. Installation & commissioning

3.1 Activating NiMH batteries

When using rechargeable NiMH batteries for emergency lighting following point are essential in order to achieve the specified design life time of the batteries:

In order to activate new batteries, 2-3 full charging-discharging are needed to make sure batteries achieve their rated capacity. This activating process is defined by running 2-3 full charging (24 hrs) and discharging (1/2/3 hrs) cycles of the batteries. If the first duration test fails, please repeat the test once again after a 24 hour charging period.

3.2 Avoidance of excessive cycling

During building installations, in many cases, mains supply is not available on a permanent 24-hour basis which then leads to unwanted, uncontrolled excessive battery cycles. This has a very strong effect on the design life time of the battery. Make sure that in such situations, the battery remains disconnected in the luminaire till the mains power supply is stable on a 24-hour basis. It is strongly recommended to refer to the datasheets of Tridonic emergency control gears to avoid excessive cycling. At the same time, make sure that this information is handed over to the installation staff / electrician in order to ensure a proper way of installation and commissioning.

3.3 Avoidance of deep-discharge conditions

If NiMH batteries or individual cells within a battery pack, are driven into deep discharge state they will not recover after charge / discharge cycles. Therefore it is very important that NiMH batteries are not left connected for long periods in a discharged state.

Following options may lead to a deep discharge situation and must be avoided:

- Storage periods of rechargeable batteries of over 12 month without recharging the battery packs.
- Shipment, storage of assembled emergency luminaires with battery pack connected to the emergency driver.
- Long periods of mains-interruptions of more than two weeks, once, the emergency system is installed and the battery pack is connected to the emergency driver.

4. Mechanical details

Battery leads

- Delivery quantity: 1 red and 1 black
- Length: 1,300 mm
- Wire type: 0.5 mm² solid conductor
- Insulation temperature rating: 90 °C
- Polarity: red (positiv +), black (negative -)

Battery end termination

Push on 4.8 mm receptacle to suit battery soade fitted with insulating cover

Module end termination

5.0 mm stripped insulation

Two-piece batteries are supplied with a 200 mm lead with 4.8 mm receptacles at each end and insulating covers to connect the separate sticks together. Connect two battery sticks in series by connecting plus to minus.

Batteries

Connection method: 4.8 x 0.5 mm spade tag welded to end of cell.

For stick packs this connection is accessible after the battery caps have been fitted.

To inhibit inverter operation disconnect the batteries by removing the connector from the battery spade tag.

5. Technical data Accu

| Capacity Cs | |
|-------------------------|---------|
| Rated minimum capacity | 2.20 Ah |
| Typical capacity | 2.42 Ah |
| Typical weight per cell | 53 g |
| Cell dimensions | |
| Diameter | 22.5 mm |
| Height | 43.5 mm |

International designation

- 2.2 Ah HRMU 23/43

Consult individual emergency control gear data sheet for maximum allowable temperatures and allowed number of discharge cycles.

6. Safety

- Do not short-circuit the battery pack – when installing the luminaire make sure sharp edges do not come into contact with cables.
- Do not open or damage the battery pack or throw it into a fire.
- Protect the battery against moisture and keep away from water.
- Do not expose the battery to direct sunlight or excessive heat (See storage conditions).
- Transport and store the battery only in its original packaging.
- Comply with the transport conditions of the transport company.
- Follow the instructions on the safety data sheets.



Damage/improper use

If the battery is damaged or user incorrectly vapours and liquids may escape from it. If you come into contact with battery fluid wash immediately with water and seek medical assistance if necessary.

7. Disposal

- Do not dispose of batteries with normal waste.
- Comply with local regulations when disposing of batteries.

8. Miscellaneous

8.1 Additional information

Additional technical information at www.tridonic.com → Technical Data

No warranty if battery was opened.